DSP-59Y

Audio Noise Reduction Filter

Features

Version 1



Congratulations

You are reading about the most advanced digital signal processor available. Timewave Technology Inc. occasionally offers performance enhancing updates to its products. Updates and corrections to information and specifications will be made to this Features Manual when needed.

Copyright

© 1994, 1995, 1996 by Timewave Technology Inc. All rights reserved.
Printed in USA

Yaesu is the registered trademark of Yaesu Musen Co., Ltd., Tokyo, Japan.
Kenwood is a registered trademark of Kenwood Corporation.

Under the copyright laws, this manual can't be reproduced in any form without prior written permission from Timewave Technology Inc.

Timewave Technology Inc. strives to deliver the best product to our customers. As part of this goal, we are constantly trying to improve our products. Timewave Technology Inc., therefore, reserves the right to make changes to product specifications or documentation without prior notice.

This manual may contain errors, omissions or "typos." Please send your comments, suggestions and corrections:

Timewave Technology Inc.
2401 Pilot Knob Road
St. Paul, MN 55120 U.S.A.

dsp@timewave.com	E-mail
http://www.timewave.com	FAQ and General and Update Information
(612)452-5939	Voice
(612)452-4571	Fax

DSP-59Y Introduction

This section includes a short summary of both the front panel controls and the rear panel connectors. It also provides an overview of the features found in the DSP-59Y. Please see *Product Specifications* for detailed information on the capabilities of the DSP-59Y.

Digital Signal Processing

Digital Signal Processing (DSP) is a powerful and complex method of analyzing and modifying analog signals. Audio signals like speech or radio data are analog signals. The speech and data signals have fairly well known and predictable characteristics; however, these characteristics are quite complex. By converting the analog signal to a digital signal, a powerful digital signal processor with a special program can analyze the characteristics of the analog signal. The digital signal processor can then modify the digital signal to enhance desired characteristics and to remove undesirable characteristics such as noise. The processed signal is converted back to an analog signal and sent on to a speaker, headphone, or data controller. The result is a signal with less noise and/or fewer data errors. In amateur radio terms, DSP is capable of reducing or eliminating QRN (noise) and QRM (interference).

For a more detailed discussion of digital signal processing, consult the most recent *ARRL Handbook*.

DSP-59Y Overview

The DSP-59Y is an extraordinarily versatile digital signal processor designed for amateur and shortwave radio voice, data, and CW operation. The DSP-59Y uses advanced digital signal processing technology to implement algorithms that perform five basic audio functions:

- Random noise reduction
- Adaptive multi-tone and manual notch filtering (Tone noise reduction)
- Bandpass/Highpass/Lowpass filtering
- Signal generation including RTTY modulation
- Signal detection for RTTY demodulation

The DSP-59Y combines these five basic functions to reduce noise and interference and improve radio communication. **The DSP-59Y hardware and software architecture allow easy field upgrade with new features and algorithms.** The same hardware and software architecture also allow ergonomic mode oriented operation of the DSP-59Y. The LCD alphanumeric display provides a clear view of operating settings when switching between operating modes. The quick-select push buttons and optical encoders for filter tuning allow instant mode change with total recall of last

setting and memories. Front-panel selectable and adjustable inputs allow you to quickly setup and adjust your DSP-59Y to wipe out noise and QRM like never before!

Here are a few more highlights among the many other operating features of the DSP-59Y:

- Selectable Automatic Gain Control
- Configurable bypass control
- Three selectable input channels
- Six memories for instant recall of user-defined configurations

Signal Flow

The DSP-59Y converts analog signals into digital signals before it routes and processes them. The digital signal processor also controls the front panel switches, encoders, LEDs, LCD display, and back panel inputs and outputs. This figure is a greatly simplified block diagram of the DSP-59Y.

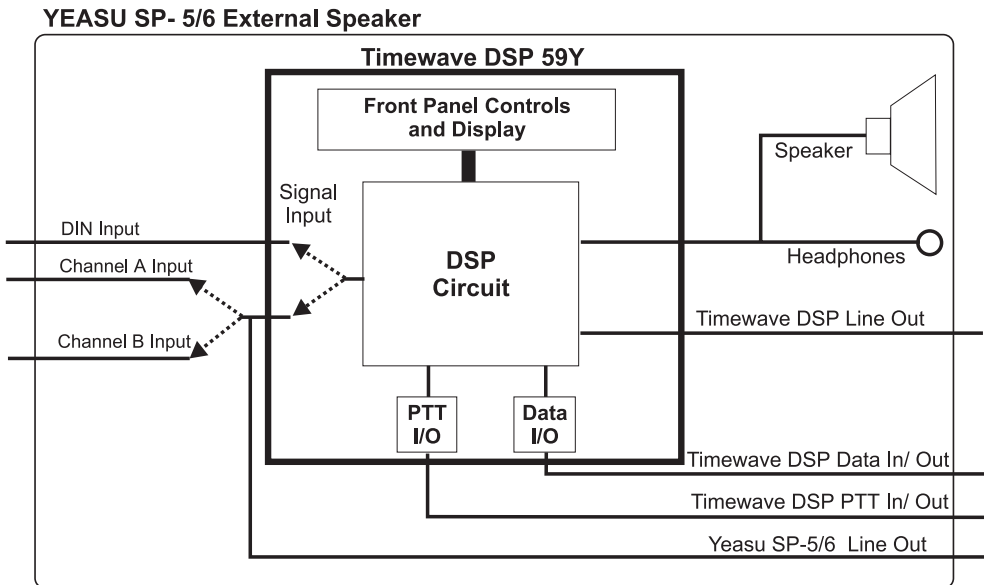

59Y-002

DSP-59Y Installation

To install a DSP-59Y, the operator must have a Yaesu SP-5/6 external speaker and provide a power source for the DSP-59Y. The operator will need to install the DSP-59Y within the Yaesu SP-5/6 external speaker. Complete instructions are included within this section. The operator will also have to make input and output connections to the Yaesu SP-5/6 and DSP-59Y. A typical connection is shown below.

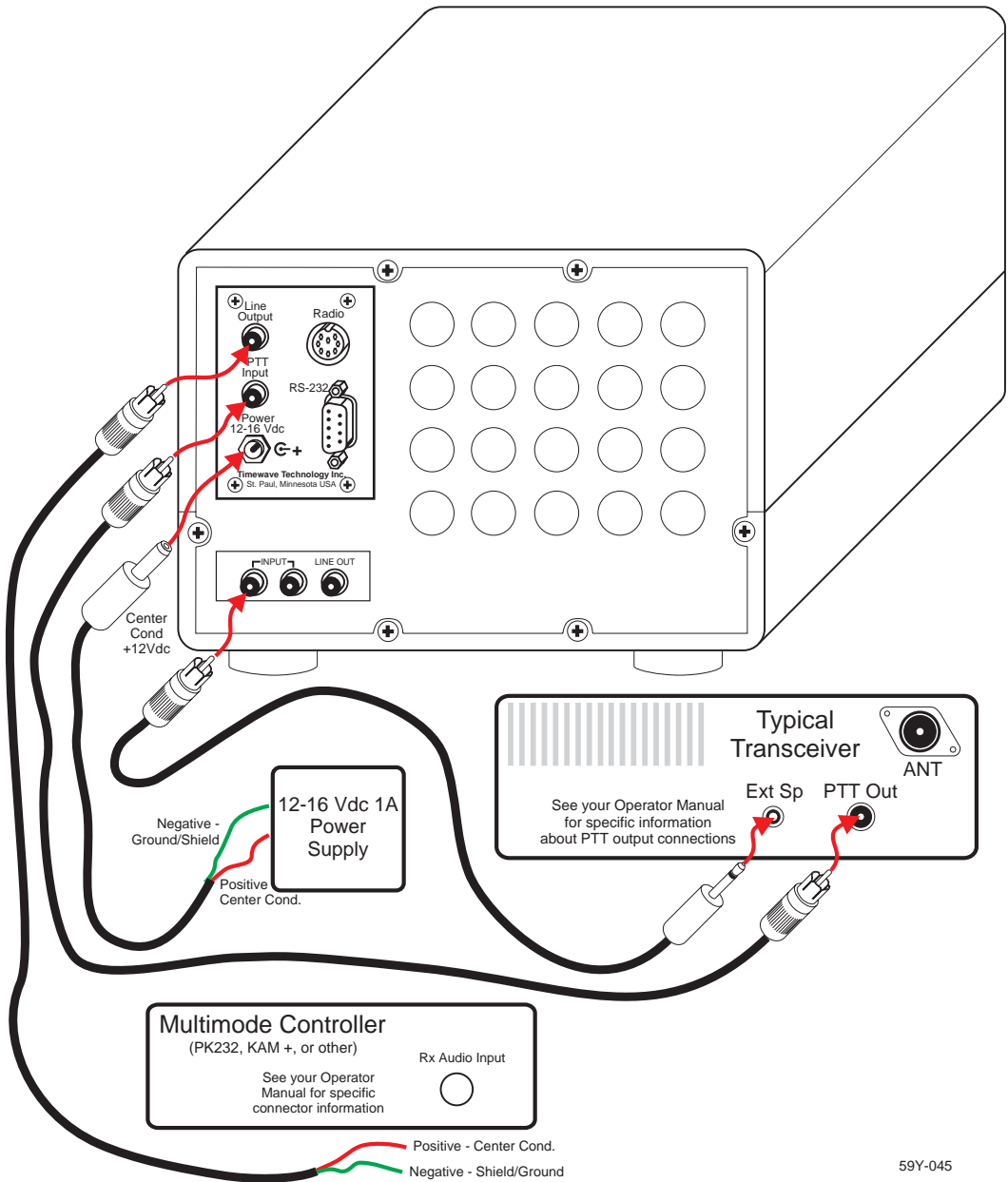

59Y-045

Front Panel Controls

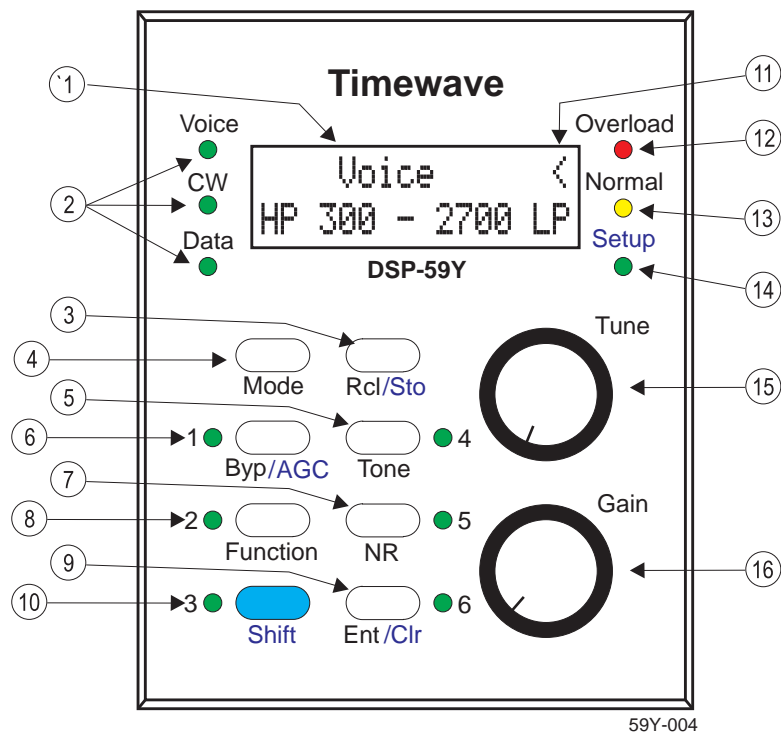

1. LCD Display

Backlit 2x16 alphanumeric display of mode, control, and test settings and data.

2. Voice, CW, Data, and LEDs.

Indicate the selected operating mode of the DSP-59Y.

3. Rcl/Sto Button

To recall memory, press **[Rcl/Sto]** and then one of the switches labeled 1 to 6. To store current settings in a memory, press **[Shift+Rcl/Sto]**, then one of the switches labeled 1 to 6.

4. Mode Button

Press **[Mode]** to change mode (Voice, CW, Data). Press **[Shift+Mode]** to switch to Setup and mode.

5. Tone Button

Press **[Tone]** for Heterodyne elimination for Voice, Marker Tone for CW and Data. Press **[Shift+Tone]** to activate manually tuned notch filter in voice and CW operating modes.

6. Byp/AGC Button

Press **[Byp/AGC]** to Bypass DSP filtering. Press **[Shift+Byp/AGC]** to activate Automatic Gain Control.

7. NR Button

Press **[NR]** to toggle on random noise reduction. Press **[Shift+NR]** to adjust aggressiveness of the noise reduction in voice and CW operating modes.

8. Function Button

This switch is used alone or in combination with the shift key to access specialized functions.

9. Ent/Clr Button

Press **[Ent/Clr]** to accept menu choices. Press **[Shift+Ent/Clr]** to discard or escape the selected choice.

10. Shift Button

This blue button shifts the function of the next switch pressed to its function labeled in blue.

11. Tune Control Indicator

The arrow in the top right corner of the display will have an arrow in if this knob controls more than one function. Arrow will indicate which function is controllable.

12. Overload/PTT LED

Red LED indicates a too high signal level into DSP-59Y from receiver. When PTT line from transceiver is connected, red LED on indicates PTT is activated.

13. Normal LED

Yellow LED indicates normal signal level into DSP-59Y.

14. Setup Mode LED

When illuminated, indicates that the DSP-59Y is in Setup Mode.

15. Tune Knob

The function of this knob changes with the mode of operation. Functions within an operating mode are toggled by pressing the knob.

16. Gain/Power On/Off

Turns power on and off, and volume control for speaker output.

Back Panel Connectors

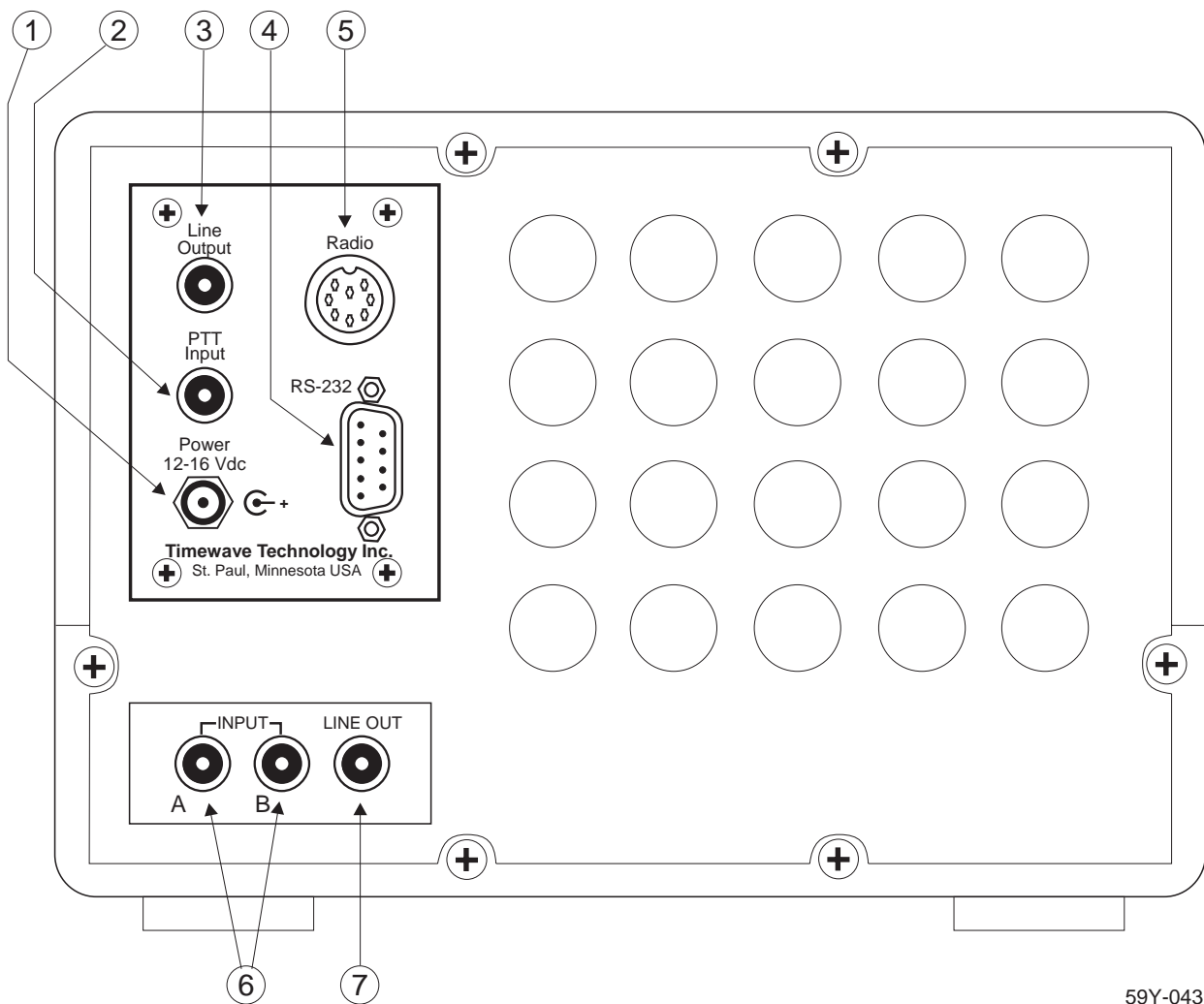

59Y-043

1. Power In

12-16 Volts DC Use 5.5 mm/2.1 mm matching plug, center positive.

2. PTT Input

PTT line from transceiver PTT output. RCA Phono connector.

3. DSP Line Output

Line level output from DSP to multimode data controller. RCA Phono connector.

4. RS-232

RS-232 compatible RTTY modem serial output for computer interface DB-9F connector. Refer to chapter 1 for pin configuration.

5. Radio

Alternative single 8 pin DIN connection for line out, audio in, PTT out, PTT in, aux. digital in. Also contains connections reserved for future options. Refer to Chapter 1 for pin configuration.

6. Inputs A & B

Normally configured for speaker level input. Passes signal through Yaesu front panel controlled analog low cut and high cut filters and channel selection switch.

7. Yaesu Line Output

Speaker level output that has passed through the Yaesu front panel controlled cutoff filter and has not passed through the Timewave DSP-59Y.

Features Common to All Modes

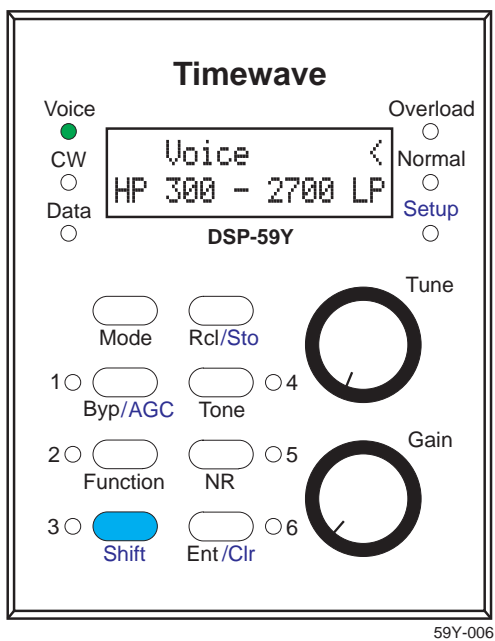

Random Noise Reduction

The noise reduction functions of the DSP-59Y operate by examining a characteristic of signals and noise called *correlation*, and dynamically filtering out the undesired signals and noise. The degree of correlation is relative. Random noise such as white noise or static is uncorrelated. Speech is moderately correlated. Repetitive or continuous noise such as a heterodyne is highly correlated. The DSP-59Y measures correlation and filters out signals and noise that are outside its correlation thresholds. The amount of noise reduction varies according to the correlation characteristics of the noise. Typical noise reduction ranges from 5 dB to 20 dB for random noise and up to 50 dB for heterodynes.

Visible Memories

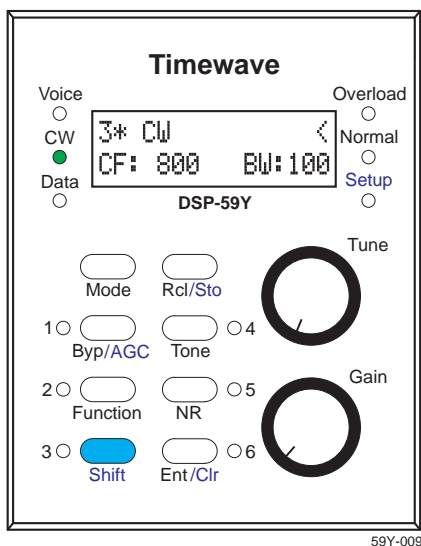

The DSP-59Y has six memories to store complete settings and configurations. Pressing **[Shift+Rcl/Sto+{#}]** (# = 1 - 6) stores every setting and setup configuration except the audio gain control position. Pressing **[Rcl/Sto+{#}]** instantly recalls the complete configuration stored in the chosen memory. The memory number is displayed along with the critical information on the LCD and LEDs.

The * following the recalled memory number indicates minor changes have been made to the operating parameters since the memory recall.

Automatic Gain Control

The DSP-59Y has switch-selectable automatic gain control to optimize the signal levels for best filter performance and to enhance listening by minimizing audible signal level variation.

Bypass Control

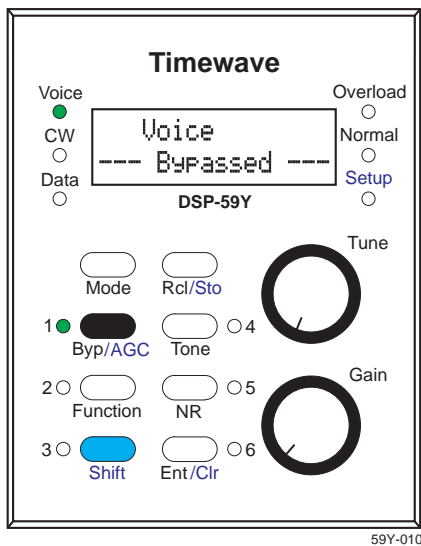

The DSP-59Y has bypass features that vary with the mode of operation. In voice and CW modes, the bypass setting routes the signal through relay contacts to completely bypass the electronic circuitry of the DSP-59Y. Turning the power off to DSP-59Y uses the same relay bypass method. In data mode, the bypass route is through the DSP processor. The amount of signal delay through the bypass route is equal to the delay through the processed signal route. The purpose of this delay equalization is to allow switching between signal processing and bypass without breaking the handshaking link of modes like Pactor and G-TOR.

Operating Modes

The DSP-59Y has three normal operating modes that operators will most often use:

- **Voice**
- **CW**
- **Data**

Pressing **[Mode]** steps from Voice mode to CW mode to Data mode back to Voice mode in a circular manner.

There is also Setup mode that operators will normally use during initial configuration, installation, and troubleshooting.

Pressing **[Shift+Mode]** places the DSP-59Y in Setup mode. Pressing **[Mode]** at any time exits current Setup Mode without saving and places the unit back into Voice Mode again. When in a menu, pressing the **[Shift+Ent/Clr]** will back you up one level.

Voice Mode

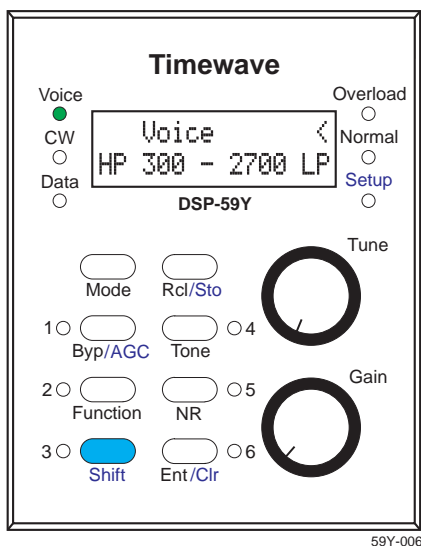

The Voice Mode digitally processes all analog voice signals for all modes including SSB, AM, FM, and PM. Independently selectable processing techniques include noise reduction, heterodyne elimination, tunable high-pass/lowpass filtering, notch filtering and automatic gain control.

Highpass/Lowpass Filters

The DSP-59Y has highpass and lowpass filters that are independently tunable with front panel controls. The LCD display shows the corner frequencies of the filters as they are tuned. There are many uses for the variable combinations of highpass and lowpass filters that the DSP-59Y offers. In a typical example of a voice mode application, highpass and lowpass filters can improve a signal with a poor signal-to-noise ratio. The independent highpass and lowpass filters remove the low and high audio frequency components that do

not contribute significantly to the speech intelligibility, thus improving signal quality. Another common voice mode example is the improvement of a SSB signal corrupted by adjacent channel interference (QRM). The steep skirts of the highpass and lowpass filters allow the operator to minimize or eliminate high side and low side interference independently with minimal impact on the desired signal.

The DSP-59Y highpass filter adjustment range is from 100 to 1000 Hz and the lowpass range is from 1000 to 5000 Hz.

Random Noise Reduction

The DSP-59Y random noise reduction has proven to be effective at reducing a wide variety of noise types, including white noise, line noise and static crashes. The amount of noise reduction varies according to the characteristics of the noise. Typical noise reduction ranges from 5 dB to 20 dB. It is possible to change the level of aggressiveness within voice operating mode without going into setup mode.

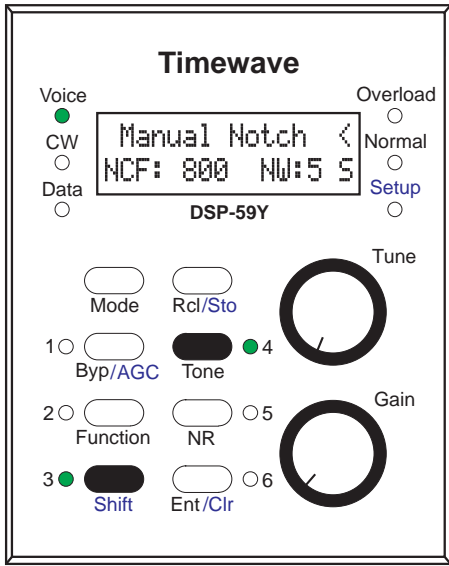

59Y-011

Adaptive Multi-tone and Manual Notch Filtering (Tone noise reduction)

The DSP-59Y has both an automatic notch filter and a manually tuned notch filter. The automatic notch filter is an adaptive multi-tone filter that can remove multiple tones simultaneously. The automatic multi-tone filter removes multiple tones simultaneously.

The manual notch filter is selectable for either as a dual notch filter for data signals and a narrow bandwidth filter for CW signals and heterodynes. The center frequency of the filter is easily set with the **Tune** knob. This filter can be used either to remove a single tone or to remove RTTY data tones from voice signals.

CW Mode

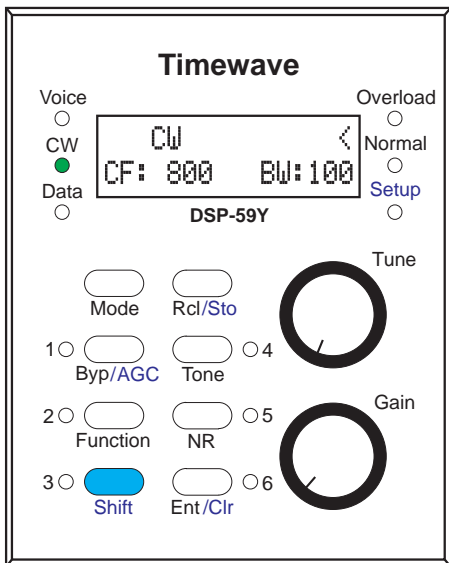

59Y-007

The CW Mode digitally processes analog CW (Continuous Wave) signals for Morse code reception. Independently selectable processing techniques include noise reduction, tunable bandpass filtering, notch filtering and automatic gain control.

Bandpass Filters

The DSP-59Y has a fully tunable bandpass filter for use in the CW mode. The LCD display shows the center frequency and bandwidth of the filter as the operator tunes with front panel tune control. Narrow band signals like CW and RTTY require a bandpass filter with steep skirts and linear phase response. Linear phase response maximizes the usable signaling rate for a given bandwidth and minimizes ringing often heard on other extremely sharp crystal and audio filters. The DSP-59Y CW filter has skirts so steep that a signal literally falls off the edge of the passband as you tune through a CW signal.

Bandwidths for the bandpass filter range from 10 Hz to 600 Hz, and center frequencies range from 200 to 2095 Hz. The narrow filter bandwidths are useful for trying to dig out extremely weak signals from the noise and QRM. The narrow bandwidth is also an excellent way of tuning to a single CW signal in a crowded band condition. The wider filter bandwidth allows easy tuning and listening to multiple CW signals simultaneously.

Random Noise Reduction

The DSP-59Y random noise reduction has proven to be useful in reducing a wide variety of noise types, including white noise, line noise and static crashes. The amount of noise reduction varies according to the characteristics of the noise. Typical noise reduction ranges from 5 dB to 20 dB. In the CW mode, random noise reduction is generally most effective in the wider CW bandwidths (400-600 Hz).

Manual Notch Filtering

The DSP-59Y has a manually tuned notch filter. The **Tune** knob on the front panel tunes the center frequency of the manual notch filter. The manual notch filter has an adjustable bandwidth allowing removal of many types of signals such as data signals, CW signals and heterodynes. Usually a narrow bandwidth filter is most effective for the greatest improvement of a CW signal, but some operating conditions (i.e., a contest) dictate a wide CW filter bandwidth. The manual notch can remove a single strong annoying signal.

Marker Tone

Pressing **[Tone]** while in the CW operating mode inserts an audio marker or spotting tone at the center frequency of the bandpass filter. Tuning the bandpass filter center frequency changes marker tone center frequency. Matching the marker tone frequency with the received signal allows switching in a narrow filter without losing the signal outside the passband of the narrow filter. The level of marker tone is adjustable relative to the processed receive signal.

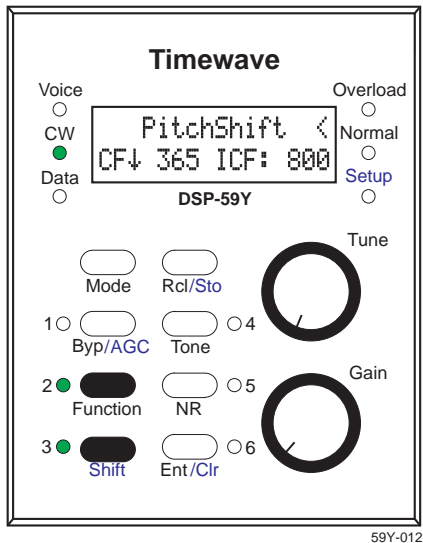

CW Tone Pitch Shift

A Timewave DSP unique feature found in the DSP-59Y is the ability to easily shift the CW tone pitch to another frequency. This feature works well with receivers that have non-adjustable, relatively high pitch CW tone, since most hams prefer to listen to 400 - 600 Hz CW tones.

Data Mode

The Data Mode digitally processes data signals including several versions of RTTY, AMTOR, SITOR, PacTOR, G-TOR®, CLOVER HF packet, SSTV and WeFAX. Independently selectable processing techniques include noise reduction, tunable bandpass filtering and automatic gain control, and a special RTTY modem and RTTY remodulator.

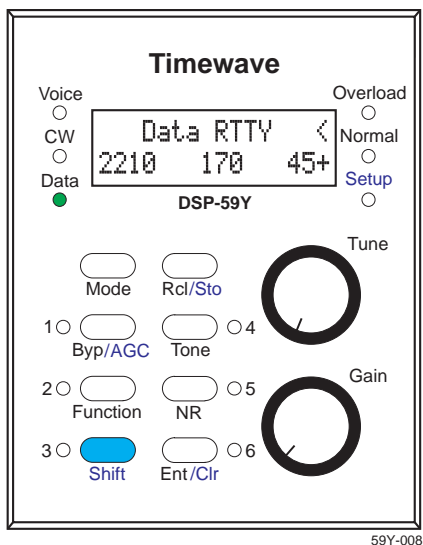

Bandpass Filters

The DSP-59Y has both fixed and tunable bandpass filters for the data mode. Narrow band data signals like RTTY require a bandpass filter with steep skirts, linear phase response, and matched amplitude response. Linear phase response maximizes the usable signaling rate for a given bandwidth and minimizes ringing often heard on extremely sharp filters. The matched amplitude response tailors the filter to match the selected modulation type and baud rate to minimize noise and interfering signals.

The DSP-59Y also has fixed frequency matched bandpass filters centered at 2210 Hz as well as lower frequencies for European standards and 1600-1800 Hz HF packet. The selectable bandwidths of the bandpass filters provide optimum filtering for 170 Hz and 200 Hz frequency shift data signals of various baud rates. Within setup, you can select between European or American standards as your default.

The DSP-59Y has individual linear phase fixed bandpass filters with steep skirts for SSTV, WeFAX and CLOVER. Since the bandwidths for these modes are fixed, the filters are primarily QRM filters for adjacent channel signals rather than noise reduction filters for eliminating random noise. The SSTV filter is a dual passband filter with one passband centered on the

SSTV sync pulse at 1200 Hz, and the other passband around the varying FM picture tones from 1500-2300 Hz. WeFAX is similar to SSTV but has no separate sync pulse so the filter bandpass covers 1500-2300 Hz. The CLOVER filter has a 500 Hz bandwidth with a center frequency of 2250 Hz.

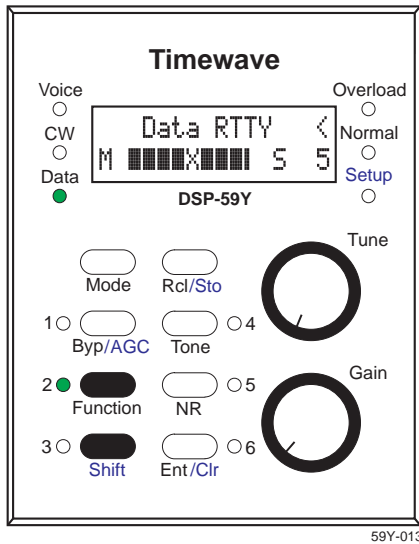

Data Tuning Function

Pressing **[Shift+Function]** turns the tuning display on. This display provides information graphically to allow precise tuning of the receiver. The display also shows the strength of the incoming data signal.

Random Noise Reduction

The DSP-59Y random noise reduction function is not specifically designed for data signals, but has been field proven to be useful for noise reduction under some conditions. It is usually most effective for 45.5 baud RTTY signals.

RTTY Modem

The DB-9F connector provides an RS-232 compatible connection for the RTTY modem output to a computer. The output is demodulated FSK in the same code format (Baudot, ASCII, etc.) as the received signal. It is not decoded or changed in any way except for demodulation. The AFSK modulated output for the transmitter appears on the line output. The PTT output signal needed to put your transceiver in transmit mode is part of the DIN connector.

The AFSK output is a modulated AFSK signal in the same code format (Baudot, ASCII, etc.) as the keying signal from the computer. The DSP-59Y does not encode or change the signal in any way except for AFSK modulation. A software terminal program that can decode and encode Baudot and ASCII code needs to be installed on the computer connected to the DSP-59Y. Timewave does not provide the terminal program. This modem is for RTTY operation only with signaling rates at 75 Baud or less.

This modem feature is designed for RTTY operation. It is not designed to be used as a TNC.

RTTY Remodulator

The DSP-59Y has another special data function for RTTY only. After passing through the optimized RTTY bandpass filter, a precision DSP-based FSK detector in the DSP-59Y demodulates the noisy incoming RTTY tones and uses the recovered digital data to drive a precision DSP-based

AFSK generator. This remodulation process takes place entirely in the DSP-59Y. The precise clean tones from the RTTY AFSK remodulator can feed any analog multimode controller or TU via the DSP-59Y line audio output.

Many analog RTTY demodulators have difficulty with noisy signals of varying amplitude, but virtually all of them can adequately demodulate the precise DSP AFSK generator output. The **[Function]** push-button selects either the remodulator with RTTY filters or the RTTY filters only. This remodulator is optimized for non-burst data at 75 Baud or less.

RTTY FSK Test Signals

Press **[Tone]** while in the non burst Data mode at 75 baud or less activates a sync nul (diddle) test tone. If the baud rate is 100 baud or higher, pressing **[Tone]** activates a space mark reference calibration tone.

Pressing **[Shift+Tone]** while in the **Data** RTTY mode at 75 baud or less inserts an audio FSK test signal into the receive channel. The “RYRY” test signal is centered at 2210 Hz with a frequency shift of +/- 85 Hz. The baud rate is determined by the RTTY parameter settings. The level of marker tone is adjustable relative to the processed receive signal. If the baud rate is 100 baud or higher, nothing happens when **[Shift+Tone]** is pressed.

Set-up Mode

The DSP-59Y uses the setup mode to configure the features which typically do not change while operating.

- **Install Setup.** Common features are set before an operating session. Also features common to all modes such as input sensitivity and line output level are set during installation. (*See Section 1 - Installation* for detailed information.) The parameters available for change are:
 - Speaker and DIN Input Signal Sensitivity
 - Line Output Level
 - Reset Memory
- **Mode Setup.** Mode-specific features need only be set if that particular mode will be used. Those features are described in detail in the specific sections describing each mode (Voice, CW, Data).
 - **Voice**
 - Input Select
 - AM Line Noise
 - **CW**
 - Input Select
 - Tone Level

- **Data**
 - Input Select
 - Speaker Mute/Bypass
 - Data Set Definitions
- **About Setup** You can find the serial number of the unit and the revision level of the firmware along with the copyright notice in this section.

DSP-59Y

Product Specifications

AUDIO INPUT

Impedance	20 K ohms or 25 ohms, jumper selectable
input signal range for full output	10 mV to 1.0 volt, front panel programmable

AUDIO OUTPUT

Speaker output power	3.0 watts into 8 ohms at 13.8 VDC
Line output	0 dB level referenced to input level . Not controlled by gain control
Headphone Jack	1/4" two-circuit jack, use stereo headphones to use all functions, mono headphones for most functions
Harmonic Distortion	less than 1% at rated output

NOISE REDUCTION FILTERS

	Frequency Range	Attenuation	Type	Delay
Random Noise Reduction	entire freq. range of selected filter	Up to 20 dB, varies with noise characteristics. Noise reduction aggressiveness front panel adjustable	Adaptive	5 msec max
Heterodyne Eliminator (multiple automatic notch)	entire freq. range of selected bandpass filter	Up to 50 dB, varies with noise characteristics	Adaptive	5 msec max
Heterodyne Eliminator (manual notch)	entire freq. range of selected bandpass filter	Up to 50 dB, varies with noise characteristics	manual	

Note: The random noise reduction and bandpass filters can operate simultaneously. The random noise reduction, tone notch and highpass/lowpass filters can operate simultaneously.

CW FILTERS

CW filters	Bandwidth = 5 Hz to 600 Hz, 10 Hz steps. Center freq. = 200 to 2150 Hz, 5 Hz steps,	55 dB at 60 Hz outside the passband	FIR Linear phase	BW less than 20 Hz= 64 msec max BW greater 20 Hz= 40 msec max
CW Marker Tone	Sine wave at center freq. of selected CW filter.			

DATA FILTERS

RTTY, AMTOR, PacTOR, G-TOR, HF Packet	Mark/Space bandwidth 60 Hz to 100 Hz, Center Freq.= 2210 Hz plus options of 1700, 1360, 1300, 1530 or 2125 Hz	40 dB at 60 Hz outside the passband	FIR Linear phase	38 msec max
Note:	RTTY and AMTOR filters have a notch at the center frequency .			
CLOVER	2000-2500 Hz	55 dB at 75 Hz outside the passband	FIR Linear phase	21 msec max
SSTV	1100-1300 Hz & 1500-2300 Hz	50 dB at 75 Hz outside the passband	Composite FIR Linear phase	21 msec max
WeFAX	1500-2300 Hz	55 dB at 75 Hz outside the passband	FIR Linear phase	21 msec max
FSK Marker Tones	1) RY string - Alternating sine waves at mark-space freq. of selected data filter (170 or 200 Hz shift). Baud rate matches selected RTTY data mode. 2) Sync-Nul Character (Diddle) - Baud rate matches selected data filter.			

RTTY MODEM

Shifts	170, 200, 425, 850 Hz
Data Rates	45, 50, 57, 75 Baud
Input	Audio from receiver.
Output	Open collector FSK and variable level AFSK
Transmit Data Polarity	Normal or Reverse
I/O	Receive data, Transmit data, PTT (RS-232 compatible)

VOICE FILTERS

	Frequency Range	Attenuation	Type	Delay
Highpass	Corner freq. = 100 to 1000 Hz, 10 Hz steps.	60 dB at 180 Hz outside the passband	FIR Linear phase	24 msec max for any combination of
Lowpass	Corner Freq. = 1000 to 5000 Hz, 10 Hz steps.	60 dB. at 180 Hz outside the passband	FIR Linear phase	highpass & lowpass

AGC

Voice mode	36 dB
CW and Data Modes	18 dB

SIGNAL PROCESSING

A-D/D-A Converter	16 bit linear, sigma-delta conversion
Signal Processor	16 bit, 27ns Analog Devices ADSP-2181 with 80 KB of memory
Processor Speed	36.8 Million Instructions per Second (MIPS)

MEMORY

Six Memories	All configuration setups can be stored and recalled (except volume control setting).
--------------	--

DISPLAY

2x16 alphanumeric characters, dot-matrix, yellow-green backlit LCD.

DIMENSIONS

Size	2.5 in. wide x 12 in. deep x 3.25 in. high (63.5 mm wide x 305 mm deep x 82.5 mm high) Fits inside the SP-5 and SP-6 by Yaesu
Weight	<2 lb. (0.908 Kg.)

POWER

Requirements	12-16 VDC @ 1A
Fuse	1.6A 5 mm x 20 mm

Note: RTTY, AMTOR, PacTOR, G-TOR and HF Packet data filter bandwidths are specified at -3 dB points to comply with traditional data filter specification methods. All other filter bandwidths are specified to comply with conventional DSP FIR filter parametric descriptions.