

PK-900 9600 BAUD DIRECT FSK MODEM OPTION

Installation And Operation Overview

Packet radio operation at 9600 baud requires three things: a TNC, a 9600 baud modem and an FM radio transceiver that is capable of high speed data operation. You already have the PK-900 and 9600 baud modem. Equally important is the FM transceiver you will be using for 9600 baud.

Most VHF and UHF FM transceivers are designed for voice operation and require special connections for high speed data use. Following the installation instructions is a "Primer" of radio connection information for FM transceivers that other amateurs have used for 9600 baud packet. Take a few minutes and read these sections before installing the 9600 baud modem.

9600 Baud Modem Installation

To install your 9600 baud modem, first remove power and all other cables from the PK-900. Remove the four screws from the top of the PK-900 and lift the top cover. Remove the four screws from the main PK-900 PC board as shown in the figure below. Install the four 0.5 inch male-female standoff spacers in place of the four screws. Do not tighten the spacers yet.

Carefully plug the modem board into the 16 pin socket J6 on the PK-900 main PC board. Make sure all 16 pins are properly seated in the socket J6. Then, check to see if the four screws line up with the spacers you just installed. If they do, remove the modem board and tighten the spacers. If they do not loosen the respective screw from the bottom of the PK-900 case, place a screw through the modem board to align the spacer and tighten the case bottom screw.

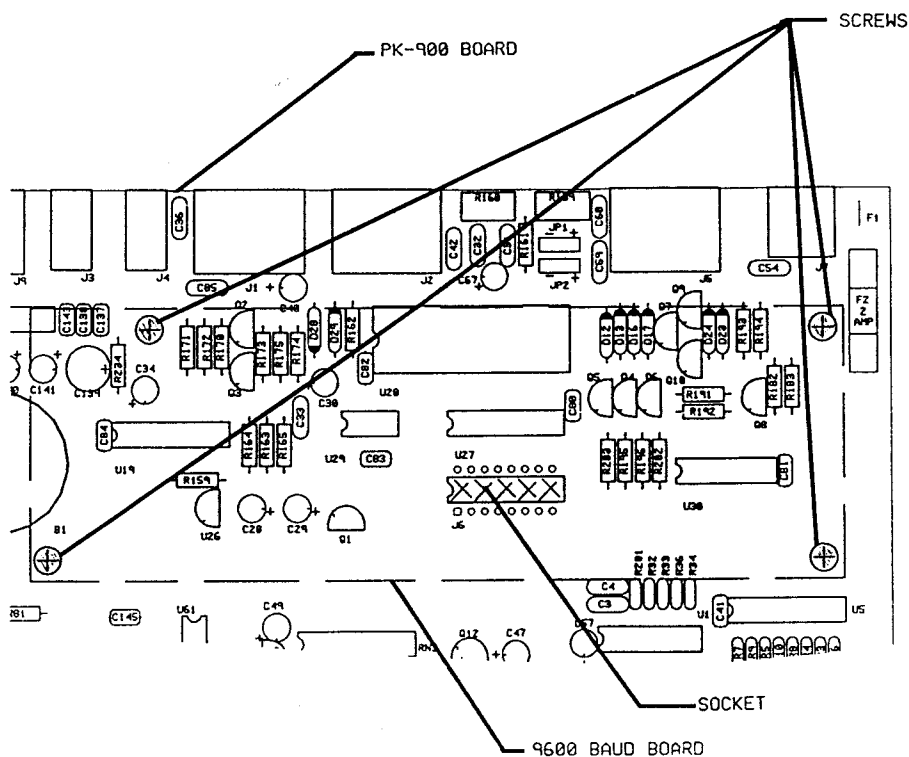

Once all the standoff spacers are aligned with the mounting holes in the 9600 baud modem board, remove the board and secure the standoff spacers to the PK-900 PC board. Now, carefully plug the modem board into J6 and secure it with the four screws you removed from the PK-900 PC board. The modem is now installed. Do not replace the cover until the 9600 baud output level has been set for the radio you will use. The output level is adjusted with potentiometer R-12 located on the 9600 baud modem board.

Adjusting 9600 Baud Transmitter Deviation

Before you can adjust the deviation, you must prepare a transceiver for 9600 baud use as described below in the Radio Modification Primer. You must also wire a radio cable. The 9600 baud internal modem option connects to your transceiver through radio port 2.

Connect your computer, 9600 baud radio and 12 VDC to the PK-900. Turn on your computer and run your communications program. (If you are using an AEA PAKRATT program, you must be in the dumb terminal mode for this procedure.)

Once the 9600 baud internal modem option is installed in the PK-900, you may select it from the list of available radio port 2 modems. To see a list of available modems, type DIR at the "cmd:" prompt. Select the internal modem option for radio port 2 by typing MODEM /9. You must also set the radio port 2 packet baud rate to 9600 baud by typing HBAUD /9600. You are now ready to set the deviation of your FM transmitter for 9600 baud.

The 9600 baud deviation is set with potentiometer R-12 on the 9600 baud modem board. Do not adjust the rear panel TX 2 adjust, it only affects the 300 and 1200 baud packet AFSK levels.

With 9600 baud signals, we strongly recommend that a deviation meter be used to verify the proper level. Make sure that the deviation meter used can be set to accept modulation frequencies of at least 10 KHz. Enter the CALIBRATE mode of the PK-900 by typing CAL at the cmd: prompt. You may key and unkey the transmitter by pressing the "K" key on the keyboard of your PC. With the transmitter keyed, adjust R-12 for a deviation of 2.5 to 3.0 KHz on the meter. If the deviation is set too low, others will not hear your signal, if set too high, you will interfere with amateurs on nearby frequencies.

If a deviation meter cannot be found, then an approximate level can be set with an FM receiver tuned to the same frequency as your transmitter:

A 9600 baud signal sounds like the "hissing" noise heard when the squelch is opened on a quiet FM channel. With the transmitter keyed, adjust the R-12 level control so that the sound heard in the receiver is approximately half as loud as the sound heard on a quiet frequency when the squelch is opened. This is approximately 2.5 KHz of deviation. This setting is temporary! As soon as possible, you should verify deviation level with a deviation meter.

Type Q to quit the CALIBRATE routine when you have finished. This completes the installation and setup of the internal 9600 baud modem option in your PK-900.

Radio Modification Primer for 9600 Baud Operation

Most VHF and UHF FM transceivers are primarily designed for voice operation and require special connections for high speed data use. After some introductory information below is a list of radio connection information for a few, selected VHF and UHF FM transceivers that other amateurs have suggested or successfully used for 9600 baud packet. Take a few minutes to read this section before operating the 9600 baud modem.

Adjusting Your TNC's Deviation

With 9600 baud signals, we strongly recommend that a deviation meter be used to verify the proper level, which is typically a peak reading of 3 KHz. (Make sure that the deviation meter used can be set to accept modulation frequencies of at least 10 KHz.) If the deviation is set too low, others will not hear your signal; if set too high, your over deviated signals will interfere with Amateurs operating on nearby frequencies and you won't be able to reliably communicate with other Amateurs.

A 9600 baud signal sounds like the white noise-type "hash" heard when your radio's squelch control is turned off on a quiet FM channel. If you can't obtain a deviation meter, then a "down 'n' dirty" way of setting your radio's deviation level is to listen to an FM receiver tuned to the same frequency as your transmitter: With the transmitter keyed the TNC's CALIBRATE mode, adjust the TNC's audio output control so that the hash's volume level heard from the receiver is about half as loud as the hash volume heard on a quiet frequency when the squelch is opened—the deviation level at that point will be approximately 2.5 KHz, which may be usable but you should really verify and set it with a deviation meter.

Radio Connections

Save one or two exceptions, you can't connect the transmit section of a 9600 baud modem directly to the microphone jack of your FM transmitter—the microphone connection is designed for audio and won't pass the 9600 baud data signal from the TNC. For the same reason, you can't connect the receive section of a 9600 baud modem directly to the speaker output of an FM receiver; the transmit audio (TXA) output signal from your TNC *must* be directly connected to the modulator stage of your FM transmitter. The receive section of the TNC must be directly connected to the discriminator of your FM receiver.

Presently, most FM transceivers don't have the aforementioned connections available to external devices. This, however, is starting to change and radio manufacturers are beginning to make these connections available to the outside world. In particular, the TEKK: KS-900, Kantronics DVR 2-2 and DVR 4-10, and the Yaesu FT-5100 are 9600 baud-connectable right out of the box.

Fortunately, it's usually not difficult to locate the connections needed for 9600 baud operation in most modern FM transceivers. We'd like to thank Mike Curtis, WD6EHR, for compiling this list and for the 9600 baud connection information that follows.

Radios that are known to work at 9600 baud are:

Alinco	DR-1200, DR-110, DR-112, DR-112T, ALR-72, ALR 709
GE	MASTR II VHF with PLL exciter, MVP VHF/UHF
Icom	IC- 22, 25, 27, 28, 38, 228, 271, 275, 290, 3200, 471, 475
Kantronics	DVR 2-2, 4-10
Kenwood	TM- 211, 212, 221, 231, 431, 621, 721, 731 TR- 7500, 7700 TS- 700, 770, 790
Motorola	MICOR UHF, MITREK
Standard	C58, C140
TEKK	KS-900
Yaesu	FT- 212, 221, 230, 736

Some radios—such as the ICOM 228 & 229—have IF filters that are too narrow to successfully pass 9600 baud receive data. In this case, you can either use a different radio or purchase and install a wider filter. MuRata-Erie (2200 Lake Park Drive, Smyrna GA 30080) makes ceramic filters—the SF series is designed for data communication. If the filter is physically and electrically compatible with the existing filter in the transceiver, the SFH450D is recommended.

Yaesu USA also makes available IF filters. Presently, they sell the following filters:

<u>Filter</u> <u>Bandwidth</u>	<u>MuRata-Erie</u> <u>Part Number</u>	<u>Yaesu</u> <u>Part Number</u>
15 KHz	LF-H15S	H3900204
15 KHz	CFW-455E	H3900200
20 KHz	LF-H20S	H3900205
20 KHz	CFW-455D	H3900203
30 KHz	CFW-455B	H3900201

Many modern rigs are true FM, so it's relatively simple to add a 9600 baud port—you need only a couple of internal connections and decoupling components to bring out the “raw” FM of the transceiver: the direct detector output and direct FM modulator input.

Most modern rigs use receiver chips such as the TA7761F/P, LA5006M, LC7532M, TK10420, TK10424, MC3357P, and others. **Note:** all of the chips mentioned here use pin 9 for the detector output—others may or may not, so check first!

Other Radios—“Inventing the Wheel”

Transmit audio is injected through a 5 to 10 μ F, non-polarized capacitor through a 5K Ω resistor into the modulator; This is typically a varactor diode in a transmit oscillator stage.

The schematic symbol for a varactor diode is  which makes them pretty simple to find by tracing forward from the microphone.

Crystal-controlled FM Transceivers

Note: True FM, multi-mode radios using varactor modulation in a crystal oscillator stage seem to work best—they tend to have a slightly wider IF filter (i.e., the CFW455E) and pass data with less distortion. (Fortunately, most synthesized radios can be made to work with extremely simple mods.) However, if your radio is crystal controlled it can be made to work if it uses true FM: it's simply a matter of connecting directly to the FM modulator—this will always be in a crystal oscillator stage.

If your crystal-controlled rig is true FM (varactor modulator in an oscillator stage), inject transmit audio into the cathode of the varactor diode. However, a lot of crystal-controlled rigs are phase modulated and need a varactor modulator added to the transmit crystal oscillator.

Use an abrupt junction type varactor diode, such as the MV2105 from Motorola, and adjust the capacitance in the crystal circuit to compensate for the additional capacitance of the varactor. If there are fixed-value capacitors, remove or “pad” them; If not, change the trimmer to one of a lower minimum value.

You'll need to bias the varactor. I've used the transmit oscillator V_{cc} and a 20K Ω trimpot to ground, feeding bias through two 10K Ω to 47K Ω fixed resistors, feeding the TNC's transmit audio through a 5 μ F to 10 μ F capacitor to the center junction of these, and feeding the free end to the cathode of the varactor. The bias needs to be adjusted for best received eye pattern on a service monitor or receiver. See the diagram below:

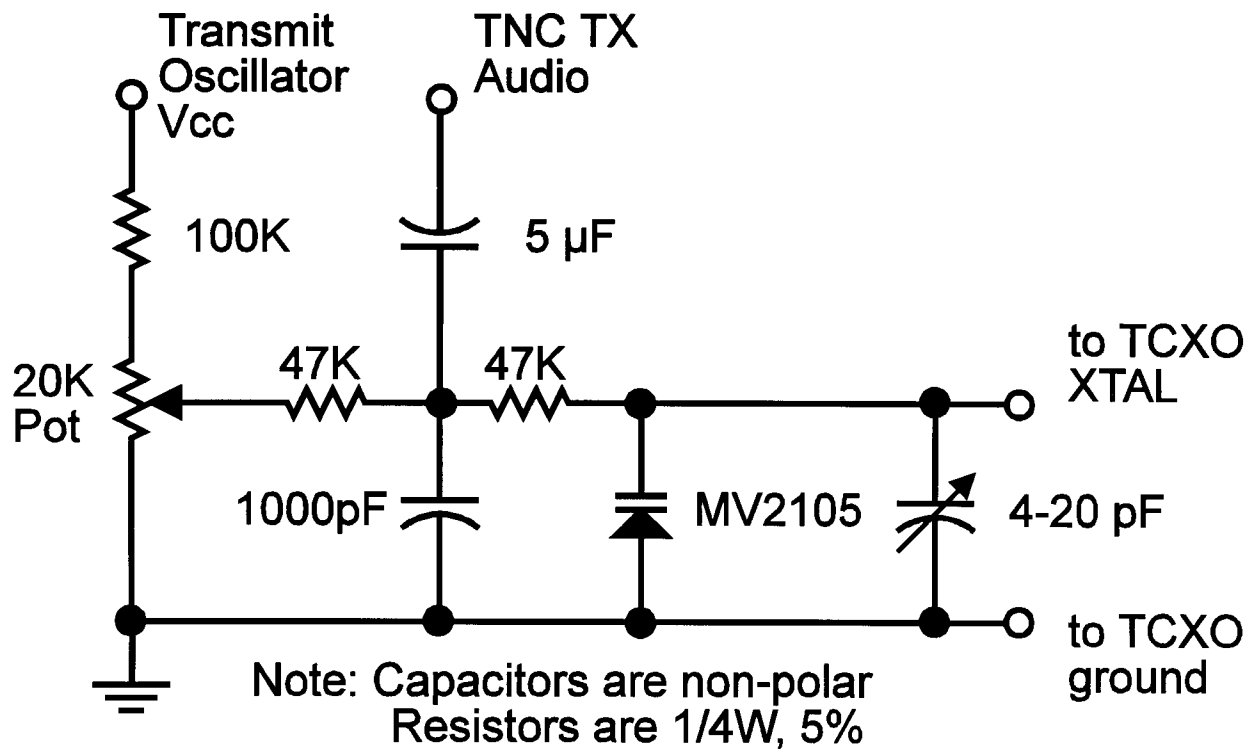

“Mod” Notes for Specific Radios

It’s almost embarrassing to call some of these “mods”—you’re only bringing out terminations of existing signals; bringing out these connections from your FM transceiver is a “non-destructive” modification to your transceiver, save the ALINCO DR-1200 and the ICOM IC-22A modifications—these radios will be dedicated to 9600 baud data radios after their modifications are performed.

ALINCO DR-110, DR-112, DR-1200

This mod uses the microphone jack for both 9600 baud transmit and receive. As you read in the preceding paragraph about the DR-1200, after the mod the you won’t be able to transmit FM voice but you’ll still be able to receive FM voice.

Receive: Disconnect the pink wire that goes to the DATA OUT pin of the mic connector on the circuitboard then reconnect it to pin-2 of the IF board’s connector. This connects the received audio from the mic plug to the radio’s discriminator.

Transmit: remove resistor R31 on the main board—this is a chip resistor located on the solder side of the main PC board. (**Note:** if you de-solder the part and resolder it so that only one edge of it is still connected to the board, you can more easily return the radio to 1200 baud—and FM voice—operation if needed.) Remove chip capacitor C40, then re-solder it to the circuitboard so that one end of the capacitor is connected to the pin-7 of the VCO board as before and the other

end is straight up in the air. Connect a jumper wire between the free end of C40 and the “hot” end—the end not grounded, or the end electrically furthest away from ground—of C35. (Note that C35 is next to the resistor R31 you removed earlier.) The mic input is now connected to the VCO for 9600 baud operation.

ICOM 22A (courtesy of Mike Curtis, WD6EHR and Dave Shalita, W6MIK)

This is one of the more difficult rigs to modify, converting your IC22A into a dedicated 9600 baud packet radio. Components with an asterisk are added to the crystal board.

1. Remove the trimmer capacitor for the transmit crystal socket you’ll be using for 9600 baud. Replace with the above circuit. The 4pF-20 pF trimcap should be a good quality ceramic or other low-drift trimmer. (Sorry, but Radio Shack doesn’t have anything suitable.)
2. Connect two 10K Ω resistors to C53 (both sides) and tie the other ends together. This junction is where you’ll pick off your receive audio.
3. Turn R67 (deviation control next to P-1 and P-2) fully counterclockwise—this kills any signals that may get into the phase modulator.
4. Using a service monitor, or oscilloscope connected to the detector of a receiver, adjust the varactor bias for the best eye pattern.

ICOM IC290A/H

Receive audio may be obtained at IC12, pin 9, on the main board; Transmit audio can be injected at D3’s cathode on the main board. If you still have the mating ACC connector plug, connections can be added to it.

ICOM IC28A/E/H

Receive audio may be obtained from IC1, pin 9, on the RF unit; Transmit audio may be injected at R-45, at the end *not* connected to trimpot R-100 (Use a 33K Ω resistor in series to correct signal levels.)

ICOM IC3200A/E

Receive audio may be obtained at IC1 pin 9 (main board)—this is a common receiver chip for both bands; Transmit audio may be injected at D3’s cathode (VHF) and D1’s cathode (UHF).

KENWOOD TM221, TM321A, TM421

Receive audio may be obtained at IC1, pin 9 (IF board); Transmit audio may be injected at connection #7 on the VCO assembly on the TX/RX unit.

KENWOOD TM621, 631 and 721 (courtesy of Jeff, WA6FWI)

Receive audio is taken from the discriminator output. Look for the 3.3K Ω resistor coming off pin 9 of the last IF stage. Connect a 1K Ω series resistor from the modem RX input to the junction of the .001 μ F capacitor and the 3.3K Ω resistor.

PTT is taken off pin 2 on the microphone connector. Transmit audio is fed through a 1K Ω series resistor to the top of VR3 (the deviation control).

Note: This method has been tested and works quite well on 440 MHz and 220 MHz. The mods haven't fully been tested on the 2-meter portion of the radio.

As with any modifications, take reasonable care—the radio's full of surface mount components.

KENWOOD TR751

Receive audio may be obtained at IC2, pin 9 on the RX unit; Transmit audio may be injected by way of the cathode D21.

KENWOOD TS-790 (courtesy of James Miller, G3RUH and Sueo Asato, JA6FTL)

These mods work well with 9600 bps UO-14 and CBBS operation. (Refer to G3RUH's notification for FT736R for more details. RX/TX mod suitability remains the same as his notes.)

Receive: Detected and amplified/buffered FM direct from the receiver discriminator is available from Pin 9, IC1 (Sub) or IC8 (Main). I use IC1 (Sub) for reception.

Transmit: Inject your transmit audio at the cathode side of diode D81 with a 1K Ω resistor in series. (You can find D81 near Q73 in your IF UNIT diagram.)

KENWOOD TW-4000 (courtesy of Mike Curtis, WD6EHR)

The radio's filters look good, although digitally optimized filters such as MuRata SFG-455D or SFH-455D would allow a tighter passband. The radio also uses a separate transmit oscillator common to both 144 and 430 MHz for generating FM—a crystal, inductor and a varactor to produce nice, linear FM, and heterodynes up from there to the respective bands.

The “mods” I’ve come up with for transmit audio and receive audio are:

Receive: Tack a 4.7K Ω resistor to IC-1, pin 17; Transmit: tack a 6.8K Ω resistor to the cathode of D16 (junction of C125-R95-D16).

If the received eye pattern from a known good transmitter is jittery, try changing C155 (associated with Q19) from .01 μ F to something like .005 μ F to .001 μ F. It also might be necessary to change C125 from .0022 μ F to .001 μ F if the transmit waveform is jittery.

I haven't tested this mod, so I'd appreciate feedback from anyone trying it. So far, I've received little feedback, so I have no idea whether this mod will work or not.

MOTOROLA MICOR (courtesy of Dan, N7MRP)

The MICOR was modified for stand-alone operation (without a control head). On P901 (the big connector in the front), pin 11 is jumpered to pin 1 (Ground), pins 8, 3 & 22 are connected together and to a 2A fuse connected to the big A+ feedthrough going into the PA. All these jumpers are done on the control (interconnect) board, except for mounting the fuse itself. Unless you want speaker audio to listen to, there's no need to install volume or squelch pots; the audio amps are not used in this application.

We performed a few mods that seemed to help prevent problems before they arose: add a capacitor (at least 20 μ F—I use 220 μ F) across C903 on the control board (this is the tubular electrolytic located just to the rear of the 9.6V regulator transistor heatsink), and add a diode (1N4001 or better) from P901 pin 16 to any of the A+ pins (3, 8, 18) with the banded end to the A+ pin. (This is a “spike” suppression diode.)

On the Audio/Squelch board: replace C203 with a 1 μ F to 10 μ F electrolytic/tantalum. I recommend at least a 20V rating—this improves the low frequency end of the discriminator's audio.

If your radio has a CTCSS encode board plugged into the exciter, remove it. Install JU304, which is located immediately adjacent to the encoder board connection on the exciter. Depending on which exciter you have, the encoder will have either 7 or 11 pins—in either case, the pin you will use to inject transmit audio is the one adjacent to the big square hole towards the outside edge of the radio (pin 6 for 7-pin, or pin 10 for 11-pin ones). Connect a shielded lead from this pin to an

unused pin on P901 (I use pin 27). On the exciter, trace the land from the pin you just connected to and you will find an 82K Ω resistor—replace it with a 10K Ω resistor (1/4W, 5%) and a 10 μ F capacitor in series. (Some exciters already have a 6.8 μ F capacitor in series—if you are *sure* yours has the capacitor, you don't need to add another!)

On the receiver RF/IF board, remove the two crystal filter “cans” that come after the IF amp IC (Y103 and Y104), and replace them with 1000pF disc capacitors (value not critical). Note that the caps *don't* connect to the center ground pin. (This mod is crucial to making the receiver work at 9600!)

Connect the transmit audio to whichever pin you connected the jumper to; receive audio (discriminator) is on pin 20, PTT is pin 16, and 12V goes to the two big pins in the middle (pins A and B).

I would advise obtaining a service manual for these radios if you plan on using them—it's Motorola part #68P81015E70, and you should be able to order one through any Motorola service shop.

MOTOROLA MITREK (courtesy of Jim, WA6OFT)

The Motorola Mitrek is one of the best radios to use for general amateur packet at 9600 baud. This mod will allow 9600 baud packet with the G3RUH type of modems, although other modems may work as well.

1. Locate the transmit audio amp/splatter section on the transmitter section of the schematic, then locate the Active Splatter filter. **Note:** the last transistor, Q504 on the VHF version, may have a different number for the other frequency bands.
2. Locate the transmit channel elements and Pin 4 on channel element #1 and the line going to Pin 4 of element #1 to the collector of Q504. This is the direct FM modulator input. Cut this trace at the channel element.
3. Solder one side of the 1 μ F electrolytic cap to pin 4 of the channel element. The other side of the cap is now the modulation input from your modem or TNC. Run it into the radio using shielded wire.
4. Install a .1 μ F capacitor between pin 3 and pin 1 of the channel element.
5. Locate pin 11 on J1—this is the plug on the front of the radio. Make your receive audio connection there. You shouldn't need to make any mods to the receiver. (If you don't have any real good test equipment don't make any receiver mods—it'll work okay.)
6. Install a .1 μ F capacitor between pins 1 and 3 on receiver channel element.

Note: At first, set your TNC's TXD argument to 200 mS. If all works well, start lowering the TXD value—you'll probably end up with a TXD of 7, or 70 mS. The capacitors on the channel elements' pins really don't affect 9600 baud operation, but they do reduce the local oscillator leak that emits out of these radios which is about 20 dB (*very important on hilltops.*)

TEKK KS-900

For the TEKK KS-900, the needed transmit level is in the 50 mV range; the level adjust is fairly sensitive in this range so it may be desirable to use a resistive divider to reduce the level from the 9600 baud modem board. This is simply a 470 Ω resistor in series and a 39 Ω resistor across the TEKK's transmit input and ground.

YAESU FT-211-RH (courtesy of Chris Lorek from SMC)

The FT-211RH has been shown to be suitable for 9600 baud packet operation. Just two shielded leads are required: one for receive audio and the other for transmitter audio connected as follows:

Receive: On the RX IF Unit (sub board F2869104,) connect the shielded inner conductor to the TK10420 IC, pin 9, with the shielded to pin 15. Caution should be taken to solder these if soldered to the underside of the board.

Transmit: On the rear of the main PCB, is a small potentiometer—this is the peak deviation adjustment pot. Unsolder the leg nearest to the rear of the set then connect the inner conductor of the shielded TX leads to this point, the outer shield to the circuitboard's groundplane adjacent to this point. To ensure that the 9600 baud modem is terminated with the required impedance, it's essential that a suitable terminating resistor be placed across the shielded lead inner/outer (such as a 560 Ω resistor); this can be done at the FT-211RH's potentiometer connection.

YAESU FT-726 (courtesy of Rick, N1HID)

Tap off between R45 and R96 for the receive and between R22 and C16 for the transmit end. You'll have to change the receive filter to a wider one (CFW-455D) which I haven't done, yet. (Contact Rick for more details and his final results.)

YAESU FT-736 (courtesy of James Miller G3RUH)

These notes tell you where to get at the FM receive audio direct from the discriminator and where to modulate the FM TX varactor directly. These mods are non-destructive and take no more than a few minutes. The signals bypass the "DATA" socket for high-grade FM operation.

The receive mod is suitable for:

- UOSAT-D 9600 baud downlink and terrestrial links
- 1200 baud AFSK/FM standard packet

The transmit mod is suitable for:

- FO-20/PACSAT uplink (1200 bps Manchester FM)
- UOSAT-D 9600 baud uplink direct FSK and terrestrial links
- 1200 baud AFSK/FM standard packet

Receive: Detected FM direct from the receiver discriminator is available from the RX UNIT at the junction of R91 and C83. These components are shown in the top, right-hand corner of the schematic.

Proceed as follows:

1. Disconnect power and all cables from the FT736 for safety.
2. Remove the top cover *only*.
3. The RX unit is the vertical module on the left.
4. Locate R91 which is about 25mm from the top, and 50mm from the rear of the radio; the resistor is “on-end” and near a couple of glass diodes.
5. Scrape any paint off R91’s free end and wet with solder.
6. Your RX audio lead should be a fine, shielded cable (such as RG-174); connect the inner conductor to R91 and the outer shield wire to a ground point (e.g., “can” of TO-09).
7. Route the cable out through any convenient opening in the case.
8. The discriminator sensitivity (FM Normal) is about 6 KHz/volt.

Note: Some FT736 receivers are fitted with an LFH12-S IF filter for FM (CF01 at the top front of the RX Unit.) This is a 12 KHz bandwidth filter which is a little narrow for 9600 bps operation. It’s recommended you change this to 15 KHz, or better still for UOSAT-D use, a 20 KHz bandwidth which will allow more tolerance for Doppler shift and give a far better “eye.” Suitable filters are: LFH-15S or CFW455E, and LFH-20S or CFW455D. The first set of these is a Yaesu spare part and is often already fitted. Try the standard first and see what happens—these filters have moderate part to part variations.

Transmit: Inject transmit audio at the junction of R32 and C29 on the TX Unit. The signal level at this point should be $800 \text{ mV}_{\text{p-p}}$ and will give $\pm 3 \text{ KHz}$ deviation—*don’t exceed this level*. Set the Mic gain on the front panel to its minimum setting.

Proceed as follows:

1. Disconnect power and all cables from the FT736 for safety.
2. Remove the top cover only.
3. The TX Unit is the module flat on the left (*not* the one tucked down the side vertically.)
4. R32 is just to the left of the rectangular shielded enclosure. The resistor is “on end.”
Scrape off any paint from the free leg and wet with solder.
5. The transmit audio lead should be a fine, shielded cable (such as RG-174); connect the inner conductor to R32 and the outer braid to the adjacent enclosure.
6. Route the cable out though any convenient opening in the case.
7. 9600 baud FSK modem: Adjust transmit audio level with VR-1.

Packet Parameters

The AX.25 parameters we all know and love at 1200 baud don't work very well at 9600 baud. These are what we've found work well at 9600.

TXDelay	Set between 8 and 15 for best throughput;
RESptime	100 mS seems to have better results than 0;
FRack	8 seconds on a busy channel; but never less than 5 seconds;
PERSIST	128 ÷ users; if it's a pretty clean channel, 64 is nice; if it's busy, estimate the average number of users and divide 128 by this number: For example, for 4 users: $128 \div 4 = \text{PERSIST } 32$
SLOTTIME	20
MAXFrame	If the channel is great: 7; average: 3; rough: 1
RETry	15
CHeck	30 (300 seconds)

PK-900 9600 Baud Modem Option Component ID

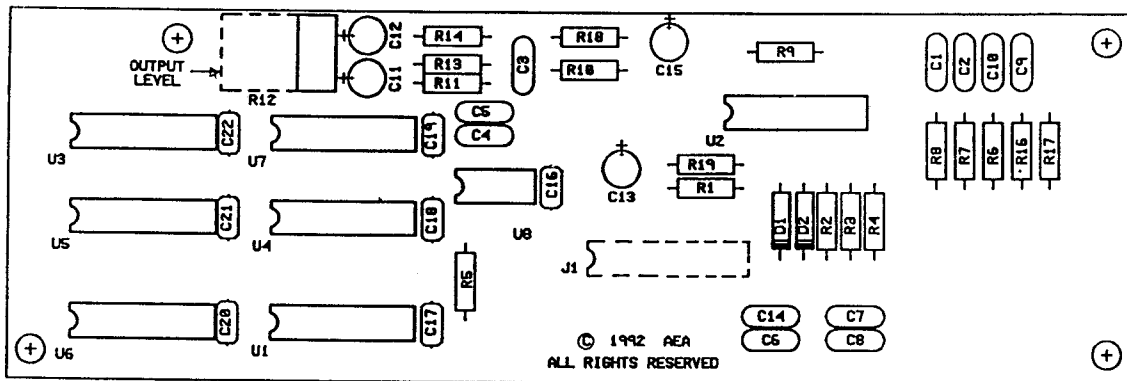

71310
 8000 SAUD OPTION
 012-126
 1092 BENTON
 1 31

